

Description

The SRDA series are specifically designed to protect sensitive components which are connected to data and transmission lines from overvoltage caused by electrostatic discharge (**ESD**), electrical fast transients (**EFT**), and **lightning**.

The unique design incorporates surge rated, low capacitance steering diodes and a TVS diode in a single package. During transient conditions, the steering diodes direct the transient current to ground via the internal low voltage TVS. The TVS diode clamps the transient voltage to a safe level. The low capacitance array configuration allows the user to protect up to four high-speed data lines. The SRDA3.3-4 feature a true operating voltage of 3.3 volts for superior protection. The SRDA05-4 may be used to protect lines operating up to 5 volts while the SRDA12-4 may be used on lines operating up to 12 volts.

These device are in a 8-pin SOIC package. They are available with a SnPb or RoHS/WEEE compliant matte tin lead finish. The high surge capability ($I_{PP}=25A$, $t_p=8/20\mu s$) means it can be used in high threat environments in applications such as CO/CPE equipment, telecommunication lines, and video lines.

Dimensions and Pin Configuration

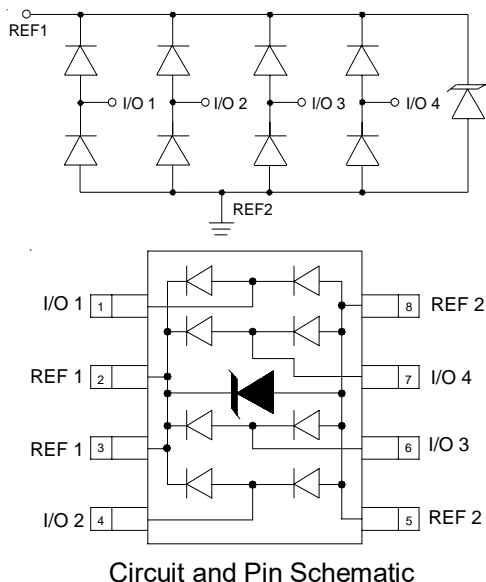

Ordering Information

Part Number	Marking	Packaging	Reel Size
SRDAxx-4	SC YYWW SRDAxx-4	2500/Tape & Reel	13 inch

Features

- ◆ Transient protection for high-speed data lines to IEC 61000-4-2(ESD) $\pm 15KV$ (air), $\pm 8KV$ (contact) IEC 61000-4-4(EFT) 40A(5/50ns) IEC 61000-4-5(Lightning)25A(8/20 μs)
- ◆ Arrays of surge rated diodes with internal TVS diode
- ◆ Protects four I/O lines
- ◆ Low capacitance(<15pF)
- ◆ Low operating voltages: 3.3V, 5V, 12V
- ◆ Low clamping voltage
- ◆ Solid-state technology

Mechanical Characteristics

- ◆ JEDEC SOIC-8 Package
- ◆ Pb-Free, Halogen Free, RoHS/WEEE Compliant
- ◆ Lead Finish: Matte Sn
- ◆ Packaging: Tape and Reel

Applications

- ◆ T1/E1 secondary IC Side Protection
- ◆ T3/E3 secondary IC Side Protection
- ◆ Analog Video Protection
- ◆ Microcontroller Input Protection
- ◆ Base stations
- ◆ I²C Bus Protection

Marking Information

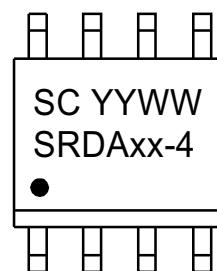

xx represents the voltage
YYWW=Date Code
Dot denotes Pin1

Absolute Maximum Ratings ($T_A=25^{\circ}\text{C}$ unless otherwise specified)

Parameter	Symbol	Value	Unit
Peak Pulse Power(8/20 μs)	Ppk	500	W
Peak Forward Voltage ($I_F=1\text{A}$, $t_p=8/20\mu\text{s}$)	V _{FP}	1.5	V
Lead Soldering Temperature	T _L	260(10 sec.)	$^{\circ}\text{C}$
Operating Temperature Range	T _J	-55 to +125	$^{\circ}\text{C}$
Storage Temperature Range	T _{stg}	-55 to +150	$^{\circ}\text{C}$

Electrical Characteristics ($T_A=25^{\circ}\text{C}$ unless otherwise specified)

SRDA3.3-4(Marking Code: SRDA3.3-4)						
Parameter	Symbol	Min	Typ	Max	Unit	Test Condition
Reverse Working Voltage	V _{RWM}			3.3	V	
Reverse Breakdown Voltage	V _{BR}	4			V	$I_T = 1\text{mA}$
Reverse Leakage Current	I _R			1	μA	$V_{RWM} = 3.3\text{V}, T=25^{\circ}\text{C}$
Clamping Voltage	V _C			5.3	V	I _{PP} = 1A (8 x 20 μs pulse)
				10		I _{PP} = 10A (8 x 20 μs pulse)
				15		I _{PP} = 25A (8 x 20 μs pulse)
Maximum Peak Pulse Current	I _{PP}			25	A	$t_p=8/20\mu\text{s}$
Junction Capacitance	C _J		8	15	pF	V _R = 0V, f = 1MHz I/O to GND
			4			V _R = 0V, f = 1MHz I/O to I/O

SRDA05-4(Marking Code: SRDA05-4)						
Parameter	Symbol	Min	Typ	Max	Unit	Test Condition
Reverse Working Voltage	VRWM			5	V	
Reverse Breakdown Voltage	VBR	6			V	IT = 1mA
Reverse Leakage Current	IR			1	μA	VRWM = 5V, T=25°C
Clamping Voltage	VC			9.8	V	I _{PP} = 1A (8 x 20μs pulse)
				12		I _{PP} = 10A (8 x 20μs pulse)
				20		I _{PP} = 25A (8 x 20μs pulse)
Maximum Peak Pulse Current	I _{PP}			25	A	tp=8/20μs
Junction Capacitance	CJ		8	15	pF	VR = 0V, f = 1MHz I/O to GND
			4			VR = 0V, f = 1MHz I/O to I/O

SRDA12-4(Marking Code: SRDA12-4)						
Parameter	Symbol	Min	Typ	Max	Unit	Test Condition
Reverse Working Voltage	VRWM			12	V	
Reverse Breakdown Voltage	VBR	13.3			V	IT = 1mA
Reverse Leakage Current	IR			1	μA	VRWM = 12V, T=25°C
Clamping Voltage	VC			17	V	I _{PP} = 1A (8 x 20μs pulse)
				20		I _{PP} = 10A (8 x 20μs pulse)
				25		I _{PP} = 25A (8 x 20μs pulse)
Maximum Peak Pulse Current	I _{PP}			20	A	tp=8/20μs
Junction Capacitance	CJ		8	15	pF	VR = 0V, f = 1MHz I/O to GND
			4			VR = 0V, f = 1MHz I/O to I/O

Typical Characteristics

Non-Repetitive Peak Pulse Power vs. Pulse Time

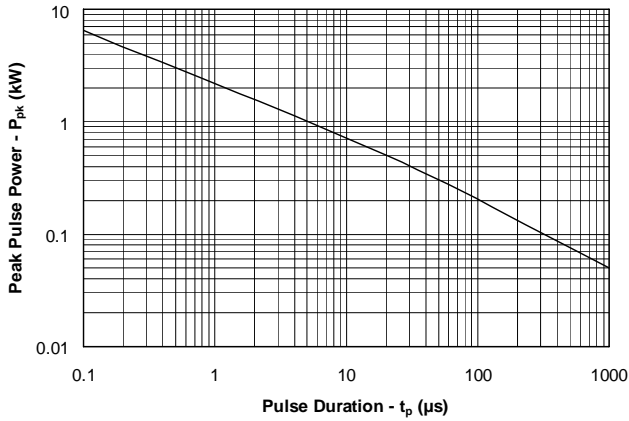

Power Derating Curve

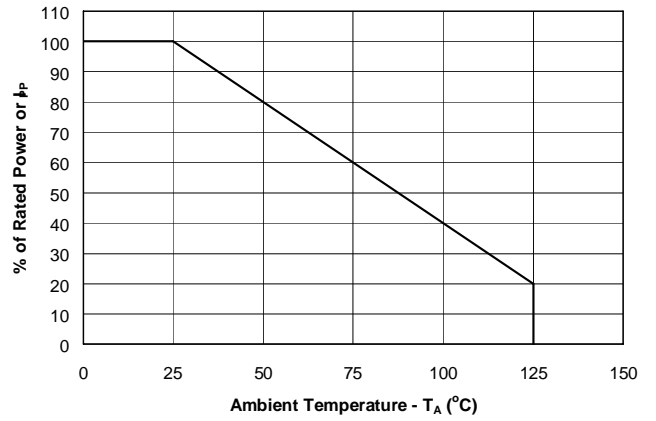

Pulse Waveform

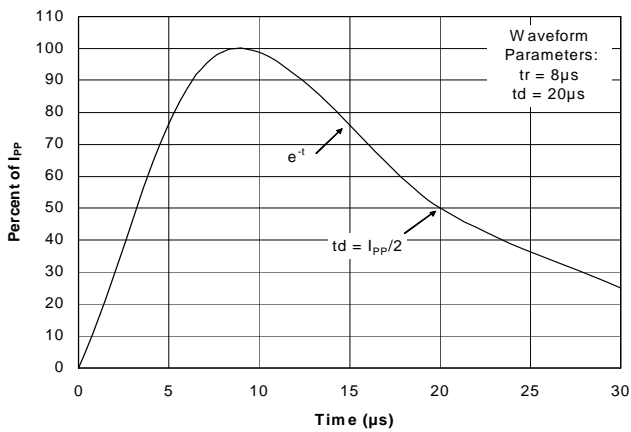

Clamping Voltage vs. Peak Pulse Current

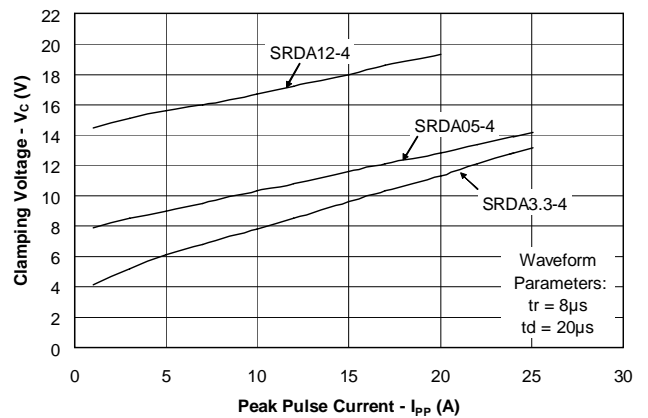

Variation of Capacitance vs. Reverse Voltage

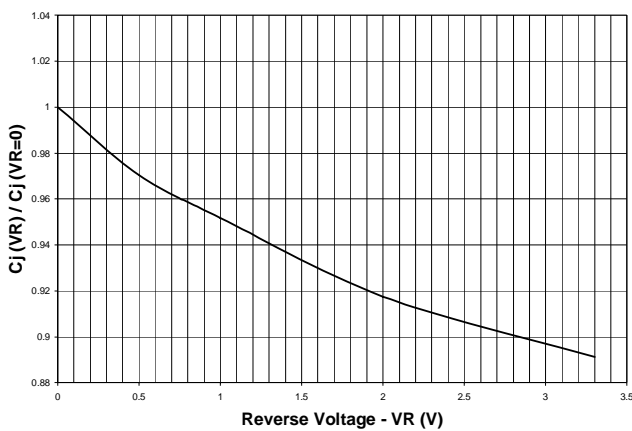

Forward Voltage vs. Forward Current

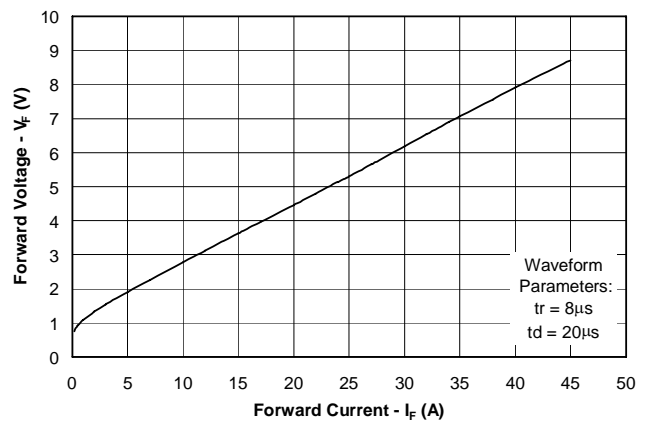

Applications Information

Device Connection Options for Protection of Four High-Speed Lines

The SRDA TVS is designed to protect four data lines from transient over-voltages by clamping them to a fixed reference. When the voltage on the protected line exceeds the reference voltage (plus diode V_F) the steering diodes are forward biased, conducting the transient current away from the sensitive circuitry. Data lines are connected at pins 1, 4, 6 and 7. The negative reference is connected at pins 5 and 8. These pins should be connected directly to a ground plane on the board for best results. The path length is kept as short as possible to minimize parasitic inductance.

The positive reference is connected at pins 2 and 3. The options for connecting the positive reference are as follows:

1. To protect data lines and the power line, connect pins 2&3 directly to the positive supply rail (V_{CC}). In this configuration the data lines are referenced to the supply voltage. The internal TVS diode prevents over-voltage on the supply rail.
2. The SRDA can be isolated from the power supply by adding a series resistor between pins 2 and 3 and V_{CC} . A value of $10k\Omega$ is recommended. The internal TVS and steering diodes remain biased, providing the advantage of lower capacitance.
3. In applications where no positive supply reference is available, or complete supply isolation is desired, the internal TVS may be used as the reference. In this case, pins 2 and 3 are not connected. The steering diodes will begin to conduct when the voltage on the protected line exceeds the working voltage of the TVS (plus one diode drop).

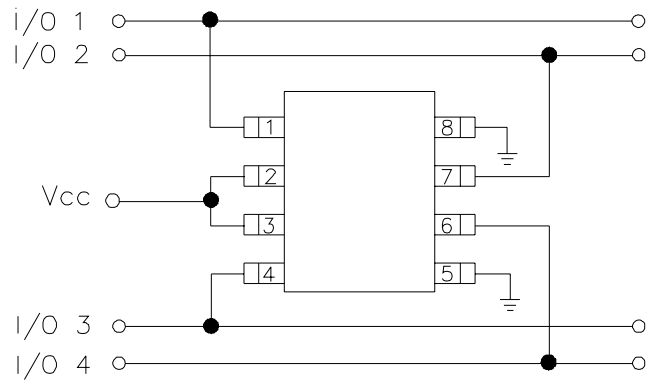

Data Line and Power Supply Protection Using V_{CC} as reference

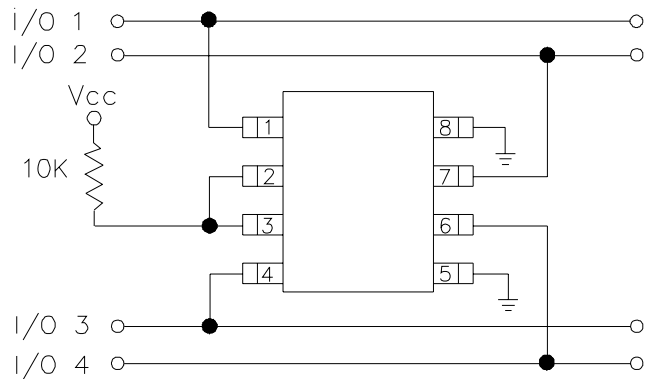

Data Line Protection with Bias and Power Supply Isolation Resistor

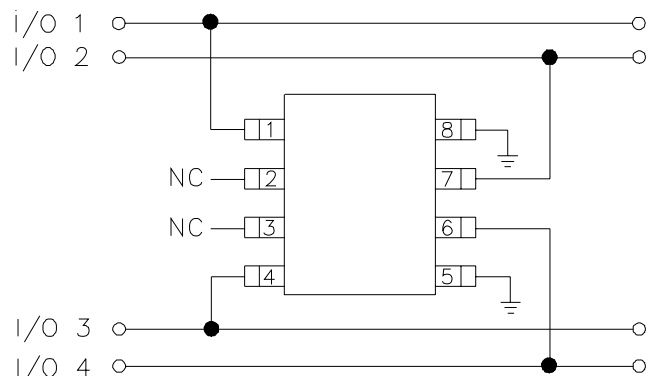

Data Line Protection Using Internal TVS Diode as Reference

Typical Application

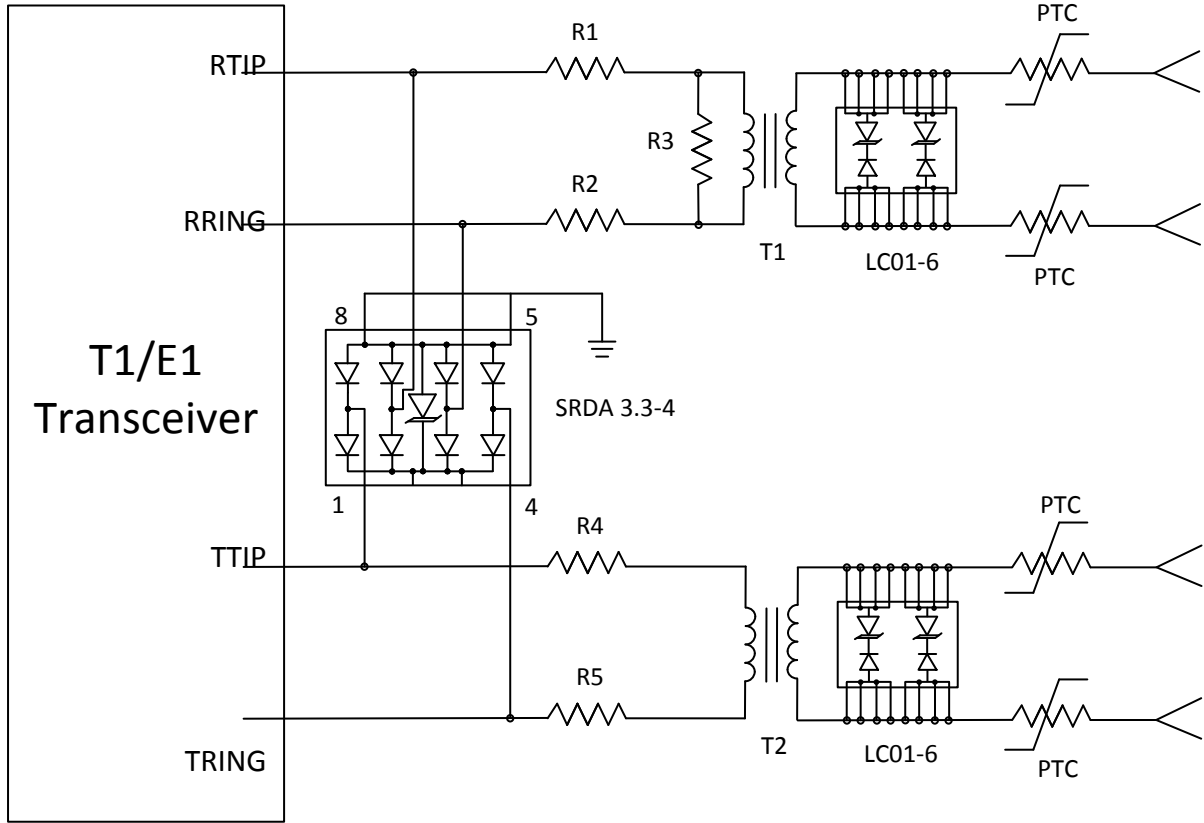

T1/E1 Interface Protection (GR-1089 Long Haul)

Typical Applications

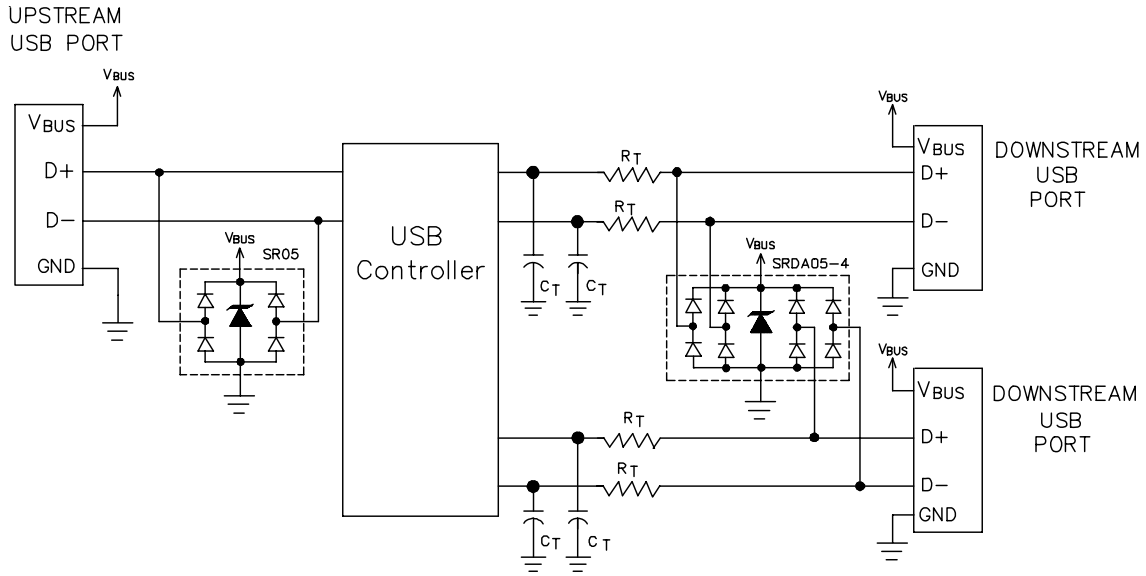

Universal Serial Bus ESD Protection

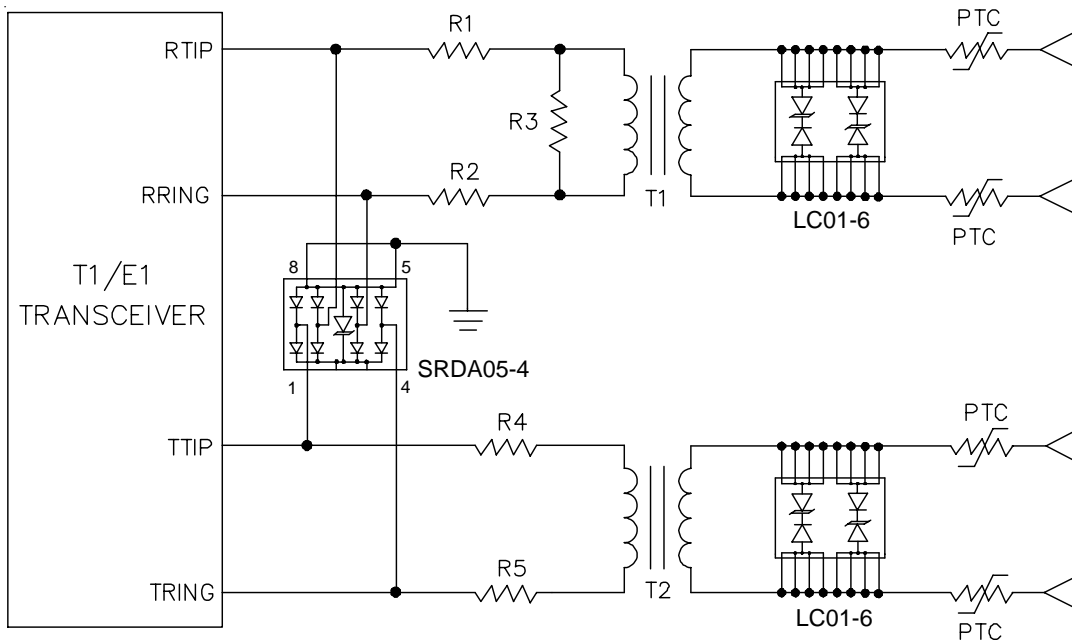

T1/E1 Interface Protection

SO-8 Package Outline Drawing

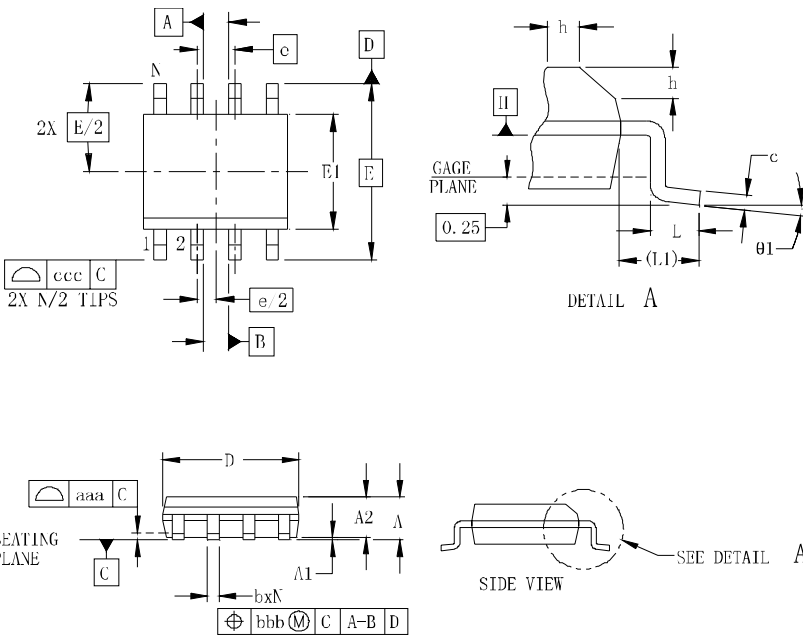

SYM	DIMENSIONS					
	MILLIMETERS			INCHES		
	MIN	NOM	MAX	MIN	NOM	MAX
A	1.35		1.75	0.053		0.069
A1	0.10		0.25	0.004		0.010
A2	1.25		1.65	0.049		0.065
b	0.31		0.51	0.012		0.020
c	0.17		0.25	0.007		0.010
D	4.80	4.90	5.00	0.189	0.193	0.197
E1	3.80	3.90	4.00	0.150	0.154	0.157
E	6.00 BSC			0.236 BSC		
e	1.27 BSC			0.050 BSC		
h	0.25		0.50	0.010		0.020
L	0.40	0.72	1.04	0.016	0.028	0.041
L1	(1.04)			(0.041)		
N	8			8		
$\theta 1$	0°		8°	0°		8°
aaa	0.10			0.004		
bbb	0.25			0.010		
ccc	0.20			0.008		

Suggested

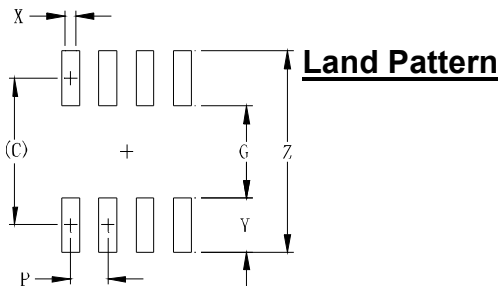

SYM	DIMENSIONS	
	MILLIMETERS	INCHES
C	(5.20)	0.205
G	3.00	0.118
P	1.27	0.050
X	0.60	0.024
Y	2.20	0.087
Z	7.40	0.291

Contact Information

Changzhou D-first Electronics CO.,Ltd.
www.first-electronic.com
 Email: xhf@first-electronic.cn
 Phone: +86 (0519) 8817 1671